



 ***unifloora***®
RAISED FLOOR SYSTEMS





► CONTENTS

PARTICLE BOARD CORE PANELS

- ◆ UGV30-UGV40
- ◆ UAV30-UAV40
- ◆ UGL30-UGL40
- ◆ UAL30-UAL40
- ◆ UEN30-UCaEN30
- ◆ UAA30-UAA40

CALCIUM SULPHATE CORE PANELS

- ◆ UCaAV30
- ◆ UCaGV30
- ◆ UCaAL30
- ◆ UCaGL30

BELTED AND BELTLESS FOOTING SYSTEM ACCESSORIES

- ◆ Outlet Box
- ◆ Raised Floor Ramp
- ◆ Facade and Step Profile Application
- ◆ Raised Floor Step
- ◆ Culvert
- ◆ Baseboard
- ◆ Ventouse
- ◆ Buttress (Earthquake Bracket)

REFERENCES

► ABOUT US

Raised floor, which is a new product in the building sector was first developed by Italy in the 1950s. In the following years, manufacturing facilities were established in Germany, England and Spain and the product found a wide area of usage throughout Europe.

Turkey, first, encountered with this product through the Nato projects in the early 1980s and was imported due to shortage of demand during the initial years, however, afterwards, in the 1990s the product was began to be manufactured by a local manufacturer. In parallel with the increase in demand in the early 2000s, the number of manufacturers within the sector, also increased. Despite this increase of number of manufacturers, technology investments were not made for the sector and local production was limited with the manufacturing of options which have wide area of usage throughout Europe.

UNITEK A.S. has been professionally working within the raised floor sector for many years and was established as a result of the unification of the knowledge of managers who possess the excitement to improve the sector and a powerful capital. With the establishment of the company, Unifloora, which is the main product, was born and took its place in the sector within a short period of time.

UNITEK A.S. began production with the largest product portfolio and highest capacity amongst the local manufacturers. Additionally, profound developments were made on subjects such as in load strength, tensile strength of coatings, conductivity and measurement precision with the conducted studies prior to production and fundamental improvements were made on tolerances allowed by the standard (TS EN 12825).

New products and production lines are developed by the R&D division, working independently from production. The new products are taken under protection with the model/patent applications and export opportunities are eased through the studies conducted by this division.

By means of the test laboratory, under the body of the company and is Turkey's most developed laboratory in terms of hardware, the samples taken in every stage of production is tested and the results are reflected upon the product labels.

► PRODUCTION

In accordance with its cause of establishment, UNITEK A.S. is aiming to manufacture products with long life cycle and low costs. A production method which has a low energy consumption and comparatively small area of production was studied on with the studies conducted prior to production and a production line was established in line with this purpose. As a result of the studies carried out, it has been finalised that a production which consumes 45% lower energy and which requires 30% smaller area of production than production in conventional terms was established.

Low cost production was reached with the high capacity production developed for conventional products. By means of this production, products with more convenient prices are provided for end users and the proliferation of the product is actualised.

Specifically developed products, on the other hand, provide observations towards the difficult conditions of use and the opportunity for the architects to easily resolve the details which established difficulties before.



► UGV30-UGV40 PANEL

High density flakeboard core, with the dimensions 600x600x30(38)mm, is coated with 0.5 mm galvanised steel from the bottom, Antistatic PVC from the above and rigid ABS(PVC) side bands from the side.

While the panel upper surface is coated with Antistatic heterogeneous PVC, homogeneous PVC, conductive PVC and wooden-like PVC which have high abrasion resistance and rich colour options, the lower surface of the panel is applied with a 0.5 mm thick galvanised steel in order to provide load strength and conductivity.

UGV30 and UGV40 model panels are designed for indoors and data processing centres which have medium and high density human traffick.



Panel Colour

UGV30-40

PANEL FEATURES	UGV30	UGV40
Panel Dimensions	600 x600 x30mm	600x600x40mm
Upper Surface	PVC	PVC
Lower Surface	Galvanised Steel	Galvanised Steel
Side Coating	Rigis ABS(PVC) Side Band	Rigis ABS(PVC) Side Band
Panel Weight	9,85 kg/ Panel	12,12 kg/ Panel
Panel Core	High Density Flakeboard	High Density Flakeboard
Run Load (TS EN 12825)	2,81 kN (safety factor 3)	3,26kN (safety factor 3)
Maximum Load (TS EN 12825)	8,45 kN	9,80 kN
Fire Class (EN13501-1)	B _{ff}	B _{ff}
Panel Load Deflection Class	3C (4,2mm)	4A (1,5mm)



► UAV30-UAV40 PANEL

High density flakeboard core, with the dimensions 600x600x30(38)mm, is coated with 0.1 mm aluminium from the bottom, Antistatic PVC from the above and rigid ABS(PVC) side bands from the side.

While the panel upper surface is coated with Antistatic heterogeneous PVC, homogeneous PVC, conductive PVC and wooden-like PVC which have high abrasion resistance and rich colour options, the lower surface of the panel is applied with a 0.1 mm thick aluminium in order to provide load strength and conductivity.

UAV30 and UAV40 model panels are designed for indoors and data processing centres which have medium and high density human traffick.



Panel Colour

UAV30-40

PANEL FEATURES	UAV30	UAV40
Panel Dimensions	600x600x30mm	600x600x40mm
Upper Surface	PVC	PVC
Lower Surface	Aluminium Foil	Aluminium Foil
Side Coating	Rigid ABS(PVC) Side Band	Rigid ABS(PVC) Side Band
Panel Weight	8,35 Kg/ Panel	10,40 kg/ Panel
Panel Core	High Density Flakeboard	High Density Flakeboard
Run Load (TS EN12825)	1,56 kN (safety factor 3)	3,12 kN (safety factor 3)
Maximum Load (TS EN12825)	4,70kN	9,35kN
Fire Class (EN13501-1)	B _{ff}	B _{ff}
Panel Load Deflection Class	1A (2,5mm)	4A (1,5mm)



► UGL30-UGL40 PANEL

High density flakeboard core, with the dimensions 600x600x30(38)mm, is coated with 0.5 mm galvanised steel from the bottom, Antistatic HPL from the above and rigid ABS(PVC) side bands from the side.

While the panel upper surface is coated with Antistatic HPL (laminare) and wooden-like HPL which have high abrasion resistance, the lower surface of the panel is applied with a 0.5 mm thick galvanised steel in order to provide load strength and conductivity.

UGL30 and UGL40 model panels are desinged for indoors and data processing centres which have medium and high density human traffick.

UGL30-40

PANEL FEATURES	UGL30	UGL40
Panel Dimensions	600x600x30mm	600x600x40mm
Upper Surface	HPL	HPL
Lower Surface	Galvanised Steel	Galvanised Steel
Side Coating	Rigid ABS(PVC) Side Band	Rigid ABS(PVC) Side Band
Panel Weight	8,52 Kg/ Panel	11,57 Kg/ Panel
Panel Core	High Density Flakeboard	High Density Flakeboard
Run Load (TS EN12825)	3,46 kN (safety factor 3)	3,18 kN (safety factor 3)
Maximum Load (TS EN12825)	10,40 kN	9,55 kN
Fire Class (EN13501-1)	B _{ff}	B _{ff}
Panel Load Deflection Class	5C (3,1mm)	4A (1,5mm)



Panel Colour



► UAL30-UAL40 PANEL

High density flakeboard core, with the dimensions 600x600x30(38)mm, is coated with 0.1 mm aluminium from the bottom, Antistatic HPL from the above and rigid ABS(PVC) side bands from the side.

While the panel upper surface is coated with Antistatic HPL (laminant) and wooden-like HPL which have high abrasion resistance, the lower surface of the panel is applied with a 0.1 mm thick aluminium in order to provide load strength and conductivity.

UAL30 and UAL40 model panels are desinged for indoors and data processing centres which have medium and high density human traffick.



Panel Colour

UAL30-40

PANEL FEATURES	UAL30	UAL40
Panel Dimensions	600x600x30mm	600x600x40mm
Upper Surface	HPL	HPL
Lower Surface	Aluminium	Aluminium
Side Coating	Rigid ABS(PVC) Side Band	Rigid ABS(PVC) Side Band
Panel Weight	8,30 Kg/ Panel	10,20 Kg/ Panel
Panel Core	High Density Flakeboard	High Density Flakeboard
Run Load (TS EN12825)	3,11 kN (safety factor 3)	3,53 kN (safety factor 3)
Maximum Load (TS EN12825)	9,33kN	10,60 kN
Fire Class (EN 13501-1)	B _{ff}	B _{ff}
Panel Load Deflection Class	4B (3,1mm)	5C (3,1mm)



► UEN30-UCaEN30 PANEL

High density flakeboard core, with the 600x600x30mm dimensions, is coated with 0.5mm Galvanised steel from the above, bottom and sides.

Panel, due to its production technique, is created by clamping side surfaces with the bottom and upper pans. With the application of this production technique, the core of the panel is reserved and the life cycle of the product is extended.

Flakeboards of 22, 28 and 30mm are used in normal office environments. Calcium sulphate core with 28 or 30 mm of thickness, on the other hand, is used in office or data processing environments where fire resistance is of priority.

UEN30 and UCaEN30 model panels are used in office environments by coating tile carpets or tile PVCs on top. Additionally, it is also used as protective coating on workshop floors and at construction sites.

UEN30-UCaEN30	PANEL FEATURES	UEN30	UCaEN30
	Panel Dimensions	600x600x30	600x600x30
	Upper Surface	Galvanised Steel	Galvanised Steel
	Lower Surface	Galvanised Steel	Galvanised Steel
	Side Coating	Galvanised Steel	Galvanised Steel
	Panel Weight	9,25 kg/panel	11,75kg/panel
	Panel Core	High Density Flakeboard	Calcium Sulphate
	Run Load (TS EN 12825)	3,81 kN (safety factor 3)	1,55 kN
	Maximum Load (TSEn 12825)	11,45kN	4,65 kN
	Fire Class (EN13501-1)	B _{ff}	A _{ff}
Panel Load Deflection Class	5C(3,05mm)	1 A(2,49mm)	



Panel Colour

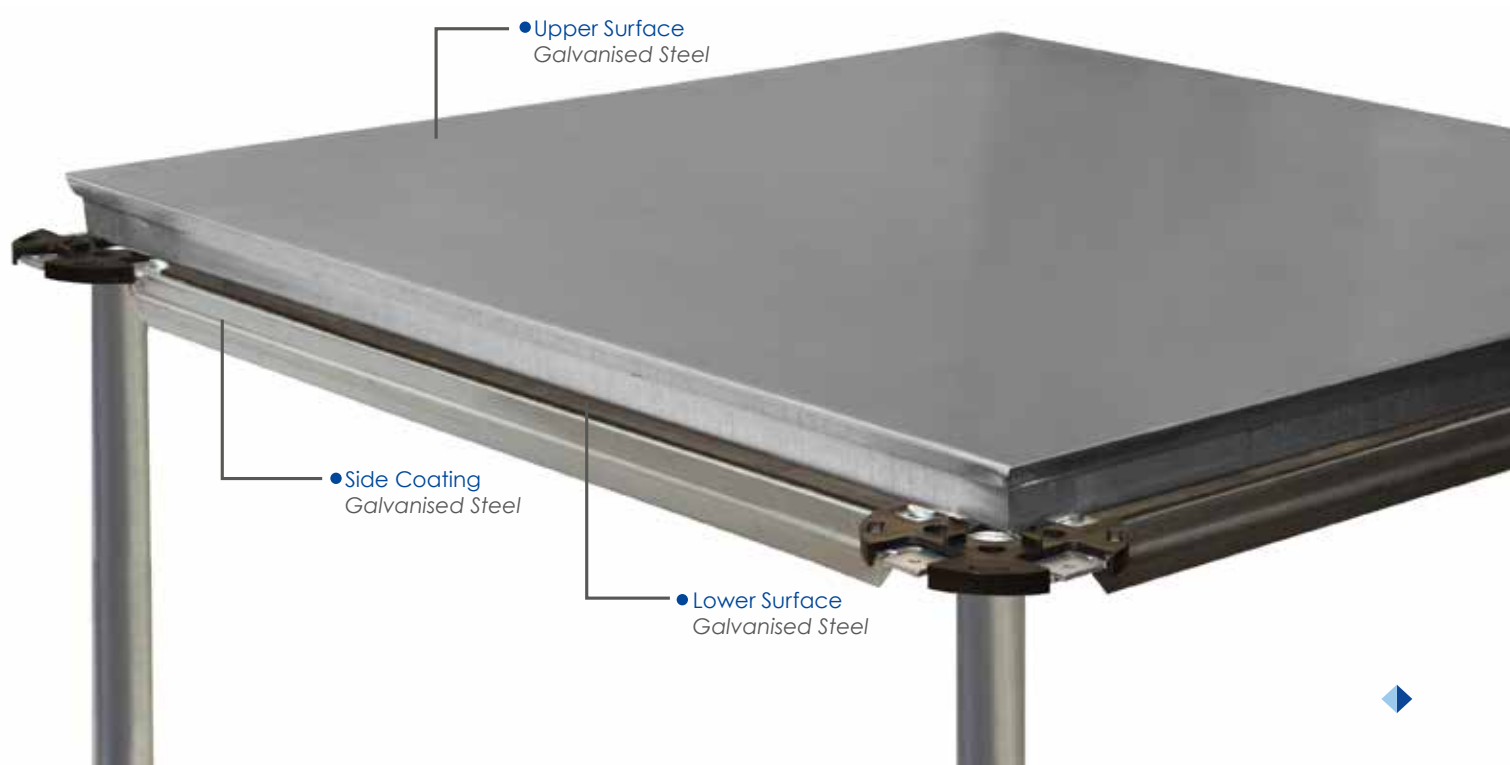

► UAA30-UAA40 PANEL

High density flakeboard core, with the 600x600x30(40)mm dimensions, is coated with 0.1 aluminium from the top and bottom and with rigid ABS(PVC) side bands from the sides.

UAA30 and UAA40 model panels are used in offices with light loads by coating its surface with tile carpet or tile PVC.



Panel Colour

UAA30-40

PANEL FEATURES	UAA30	UAA40
Panel Dimensions	600x600x30mm	600x600x40mm
Upper Surface	0,1mm Aluminium Foil	0,1mm Aluminium Foil
Lower Surface	0,1mm Aluminium Foil	0,1mm Aluminium Foil
Side Coating	Rigid PVC Side Band	Rigid PVC Side Band
Panel Weight	7,12 Kg/ Panel	10,20 Kg/ Panel
Panel Core	High Density Flakeboard	High Density Flakeboard
Run Load (TS EN 12825)	1,86 kN	3,40 kN
Maximum Load (TS EN 128025)	5,60 kN	10,20 kN
Fire Class (EN13501-1)	B _{ff}	B _{ff}
Panel Load Deflection Class	1B (3,15mm)	5A (2,5mm)



► UCaAV30 PANEL

Calcium sulphate core, with the dimensions 600x600x30mm, is coated with 0.1 mm aluminium from the bottom, Antistatic PVC from the above and rigid ABS(PVC) side bands from the side.

While the panel upper surface is coated with Antistatic heterogeneous PVC, homogeneous PVC, conductive PVC and wooden-like PVC which have high abrasion resistance and rich colour options, the lower surface of the panel is applied with a 0.1 mm thick aluminium in order to provide load strength and conductivity.

UCaAV30 model panels are desinged for indoors and data processing centres which have medium and high density human traffick and with fire resistance as priority.

UCaAV30

PANEL FEATURES	UCaAV30
Panel Dimensions	600x600x30mm
Upper Surface	PVC
Lower Surface	Aluminium Foil
Side Coating	Rigid ABS(PVC) Side Band
Panel Weight	12,3 kg/ Panel
Panel Core	Calcium Sulphate
Run Load (TS EN 12825)	1,75 kN (safety factor 3)
Maximum Load (TS EN 128025)	5,20 kN
Fire Class (EN13501-1)	A _{fl} (Calcium Sulphate)
Panel Load Deflection Class	1A (2,3mm)



Panel Colour

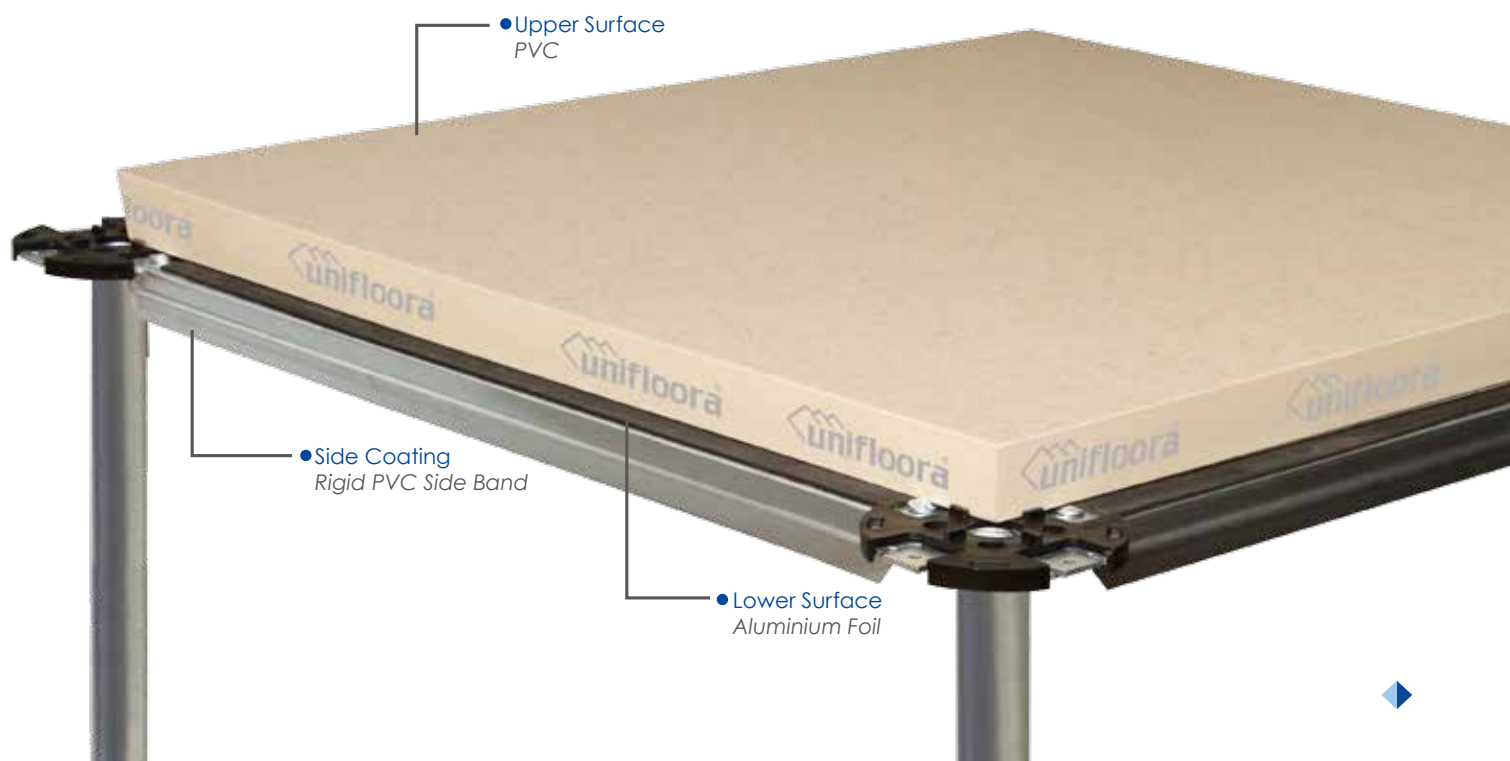

► UCaGV30 PANEL

Calcium sulphate core, with the dimensions 600x600x30mm, is coated with 0.5 mm galvanised steel from the bottom, Antistatic PVC from the above and rigid ABS(PVC) side bands from the side.

While the panel upper surface is coated with Antistatic heterogeneous PVC, homogeneous PVC, conductive PVC and wooden-like PVC which have high abrasion resistance and rich colour options, the lower surface of the panel is applied with a 0.5 mm thick galvanised steel in order to provide load strength and conductivity.

UCaGV30 model panels are designed for indoors and data processing centres which have medium and high density human traffick and with fire resistance as priority.



Panel Colour

UCaGV30

PANEL FEATURES	UCaGV30
Panel Dimensions	600x600x30mm
Upper Surface	PVC
Lower Surface	Galvanised Steel
Side Coating	Rigid ABS(PVC) Side Band
Panel Weight	13,26 kg/ Panel
Panel Core	Calcium Sulphate
Run Load (TS EN 12825)	2,97 kN (safety factor 3)
Maximum Load (TS EN 12825)	8,90 kN
Fire Class (EN 13501-1)	A _{fl} (Calcium Sulphate)
Panel Load Deflection Class	3C (4,3mm)



► UCaAL30 PANEL

Calcium sulphate core, with the dimensions 600x600x30mm, is coated with 0.1 mm aluminium from the bottom, Antistatic HPL from the above and rigid ABS(PVC) side bands from the side.

While the panel upper surface is coated with Antistatic HPL and wooden-like HPL which have high abrasion resistance, the lower surface of the panel is applied with a 0.1 mm thick aluminium in order to provide load strength and conductivity.

UCaAL30 model panels are designed for indoors and data processing centres which have medium and high density human traffick and with fire resistance as priority.

UCaAL30

PANEL FEATURES	UCaAL30
Panel Dimensions	600×600×30mm
Upper Surface	HPL
Lower Surface	Aluminium Foil
Side Coating	Rigid ABS(PVC) Side Band
Panel Weight	12,25 Kg / Panel
Panel Core	Calcium Sulphate
Run Load (TS EN 12825)	1,60 kN (safety factor 3)
Maximum Load (TS EN 12825)	4,80 kN
Fire Class (EN 13501-1)	A _{fl} (Calcium Sulphate)
Panel Load Deflection Class	1A (2,3 mm)

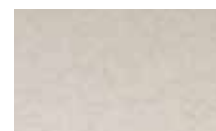

Panel Colour



► UCaGL30 PANEL

Calcium sulphate core, with the dimensions 600x600x30mm, is coated with 0.5 mm galvanised steel from the bottom, Antistatic HPL from the above and rigid ABS(PVC) side bands from the side.

While the panel upper surface is coated with Antistatic HPL and wooden-like HPL which have high abrasion resistance, the lower surface of the panel is applied with a 0.5 mm thick galvanised steel in order to provide load strength and conductivity.

UCaGL30 model panels are desinged for indoors and data processing centres which have medium and high density human traffick and with fire resistance as priority.



Panel Colour

UCaGL30

PANEL FEATURES	UCaGL30
Panel Dimensions	600x600x30mm
Upper Surface	HPL
Lower Surface	Galvanised Steel
Side Coating	Rigid PVC Side Band
Panel Weight	13,26 Kg/ Panel
Panel Core	Calcium Sulphate
Run Load (TS EN 12825)	2,98 kN (safety factor 3)
Maximum Load (TS EN 12825)	8,95 kN
Fire Class (EN 13501-1)	A ₁ (Calcium Sulphate)
Panel Load Deflection Class	3C (4,3mm)



► BELTED FOOTING SYSTEM

Foot headings of the belted footing system is connected to each other with assistance of belts and form a cage. Belts are fixed with tightening the screws after placing them to the sockets on the heading plate.

Through this process, the established system becomes durable towards vertical and horizontal loads. Belted system is generally used in heights ranging from 200-1000 mm.

Belted	THICKNESS	DIMENSIONS
	0,8 mm	28 x 23 x 28 mm



FOOT (Belted)	UN-M14 (Belted)	UN-M18 (Belted)
Heading	90 X 3 mm Galvanised Steel	90 X 3 mm Galvanised Steel
Pipe	25 X 1,5 mm Galvanised Steel	25 X 1,5 mm Galvanised Steel
Base	90 X 90 X 2mm Galvanised Steel	90 X 90 X 2mm Galvanised Steel
Stud	90 mm M14 Galvanised Steel	90 mm M18 Galvanised Steel
Height	20-120 cm	20- 120 cm
Tolerance	3.5 cm	3.5 cm
Unit Weight	620 -2.000 gr	670 - 2.100 gr
System Weight	3.900-8.400 gr	4.150-8.600 gr
Maximum Load Capacity	25 kN	25 kN



Plastic Star ●

● Belt Gasket

● Foot Heading



► BELTLESS FOOTING SYSTEM

Beltless footing system is created by directly applying the panels on the footings. This system is generally used in applications with the height of 80-200mm. It can be used up to 400mm in special cases.

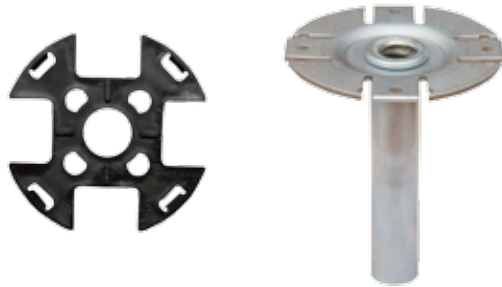

FOOT (Beltless)	UN-M14 (Beltless)	UN-M18 (Beltless)
Heading	90 X 2 mm Galvanised Steel	90 X 2,5 mm Galvanised Steel
Pipe	21 X 1,5 mm Galvanised Steel	21 X 1,5 mm Galvanised Steel
Base	90 X 90 X 2 mm Galvanised Steel	90 X 90 X 2 mm Galvanised Steel
Stud	65 mm M14 Galvanised Steel	65 mm M18 Galvanised Steel
Height	8 - 20 cm	8 - 20 cm
Tolerance	2 cm	2 cm
Unit Weight	520 gr	570 gr
System Weight	1716 gr	1881 gr
Maximum Load Capacity	29,00 kN	29.00 kN



▶ ACCESSORIES



Outlet Box

It is used for computer and communication line connections in office environments where raised flooring is used. Due to its easy implementation on cover surface of the flooring, an aesthetical integration with the environment is ensured. When the replacement of office furnitures is deemed necessary, the location of the outlet box can also be easily changed due to the modular structure of the raised floor.

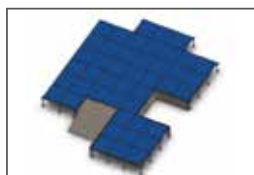

Raised Floor Ramp

Raised Floor Infrastructure system is manufactured 10-100 cm high off the floor and in a manner to leave volume in the desired measurements. The device or equipment wished to be placed on the current system is manufactured as Fixed with the purpose of practicalising the its transportability or as Portative in order to be used when required.



Facade and Step Profile Application

Facade application is utilised in order to close the gap in front of the doors in raised floor areas. Facade (step) profile is used in order to conceal the section surface and to reduce the risk of slipping.



Raised Floor Step

Raised panel and footings are used to create steps when the heigth difference between the raised floor surface and fixed floor equals to of a step (18-20cm).



Culvert

When precision air conditioner and bottom blown cooling is required in system rooms and data processing centres, the cooled air is carried to the upper volumes by being conducted to the underneath of raised floor through the assistance of culverts. It is generally manufactured with 150 x 600mm, 200 x 600mm and 600 x 600mm dimensions. It has Dumper and non-dumper options.

Dumper Culvert; It is an equipment which provides more effective cooling to the devices through the use of its wings which is utilised to give the required direction to the cold air flow generating from the lower surface.

Non-dumper culvert; It is an equipment which has a standard angle and conveys the cold air flow generating from the lower surface at a fixed angle.



Baseboard

It is used to provide an aesthetic outlook on wall sidings following the raised floor application. It has Wood, MDF and PVC options.



Ventouse

Due to the modularity of Raised Floor System, it provides you with the opportunity for fast and practical interference. Ventouse, which is used for fast and easy opening of Panels during interference, is manufactured by taking the panel weight into consideration and delivered to the technical personnel after application.



Buttress (Earthquake Bracket)

It is used in order to increase the resistance of raised floor footings against horizontal (lateral) loads. The use of this equipment is seen fit in heights higher than 60 cm and in regions where earthquake risk is high. It is recommend, the equipment to be used in wall lines with the risk of slipping or for every one of the three footings.



► REFERENCES

	aselsan		 CUMHURBAŞKANLIĞI	
	 İÇİŞİLERİ GENEL MÜDÜRLÜĞÜ KIDAS ÇELİK ENERJİ TERSANESİ VE ULAŞIM SANAYİ A.Ş.	 KOZA ALTIN İŞLETMELERİ A.Ş.	 Mercedes-Benz	
	 ÖSYM	 RÖNESANS HOLDİNG	 TOYOTA	AKBANK
	BOSCH	 FINANSBANK	 Garanti	HSBC 
Hürriyet	 T.C. CUMHURİYETİ İÇİŞİLERİ BAKANLIĞI	 Milliyet	 SABAH	
 Shell	SIEMENS	 T.C. CUMHURİYETİ İÇİŞİLERİ BAKANLIĞI	 T.C. Ulaştırma Bakanlığı	ZAMAN 
 roketsan	 SGK Sosyal Güvenlik Kurumu	 TBMM	 TEMA 2001	 TEKFEN MÜHENDİSLİK
 TEPE İNŞAAT	TEPEprime	 TRT	 TÜBİTAK	



Bu kataloğun basımı KOSGEB tarafından desteklenmiştir.
Basım Tarihi: Nisan 2014



T.C. Sanayi ve Ticaret Bakanlığı
Küçük ve Orta Ölçekli İşletmeleri Sanayi Geliştirme ve
Destekleme İdaresi Başkanlığı
www.kosgeb.gov.tr

Tasarım-Baskı **artarda**
www.artarda.com işleri • tasarım • multimedya

**unifloora**[®]
RAISED FLOOR SYSTEMS

Varlık Mah. Beypazarı Cad. No: 33 / 2
Yenimahalle / ANKARA / TURKEY
Tel: +90(312) 342 00 53 Fax: +90(312) 342 00 63
www.unifloora.com